

ISS	AMEND	DATE
1	REDRAWN	9/7/90
2	P/No. ERROR	8/9/98
3	WAS FC6913	5/10/99

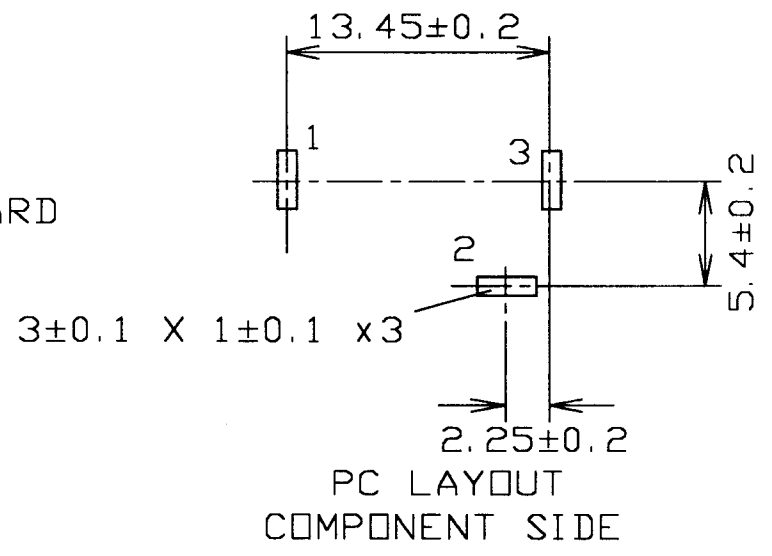
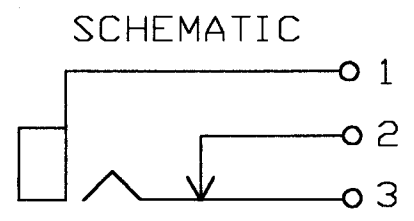
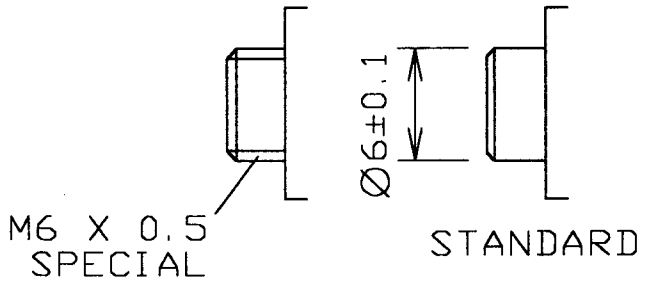
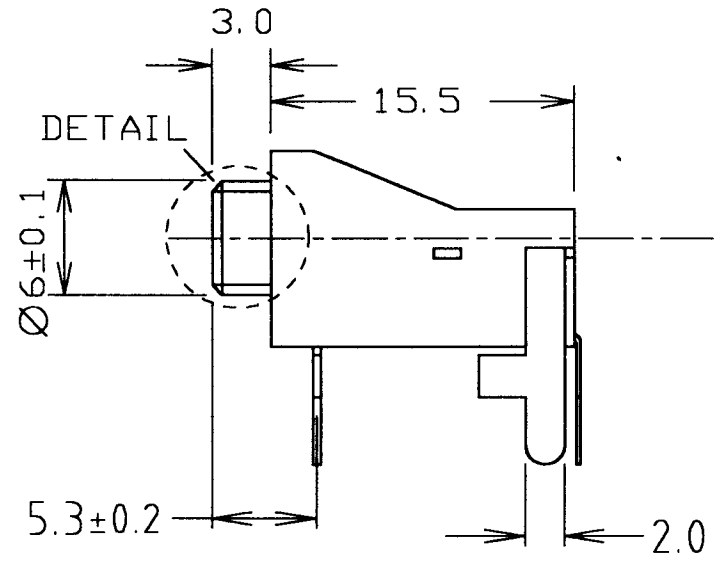
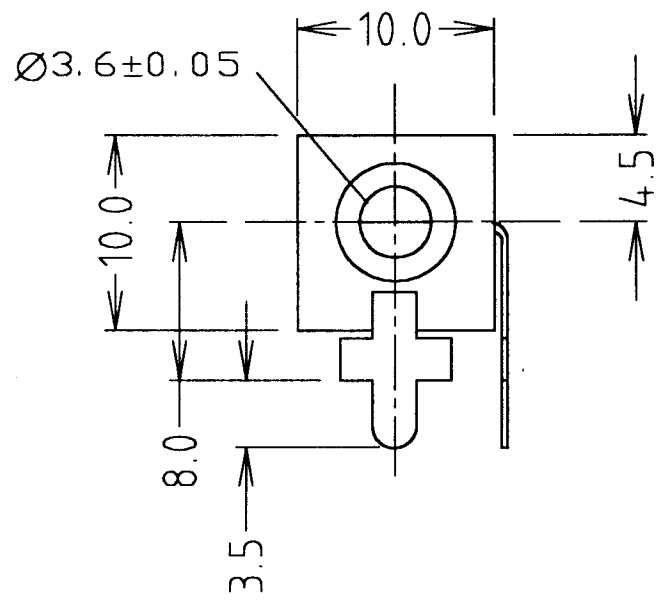

Tolerance

NO DEC. PLACE ± 0.50
1 DEC. PLACE ± 0.20
2 DEC. PLACE ± 0.10
DIA. HOLES ± 0.10
ANGLES ± 1/2°
UNLESS OTHERWISE STATED

WHERE USED F.R.
SCALE N.T.S.

DIMENSIONS IN MILLIMETERS UNLESS OTHERWISE STATED. WORK TO DIMENSIONS. DO NOT SCALE DRAWING. 3rd ANGLE PROJECTION. REMOVE BURRS. IF IN DOUBT ASK.

Cliff Electronic Components, Inc. 4876 East Second Street, Benicia, CA 94510 USA Tel: (707) 746 8090 Fax: (707) 746 8092	MATERIAL ABS / BRASS (JY3502-02)		TITLE 3.5mm MONO PC JACK SOCKET JY036A	
	FINISH AS MOULDED / NI / Ag PLATED		DRWG. No. FC 68130	
DRAWN C.A.M.J.	APPD. RWT	FORM: A4DRWGH		